



# MAGNETIC TOOLS

## MAGNETIC VICE

The Magnetic Vice ensures a distortion free use. This Vice assures the square holding of the component and thus the set up time is minimized.

### SPECIAL FEATURES:

Flatness, Squareness, & Parallelism - 0.005 mm  
Permanent powerful magnet with ON - OFF switch  
All surfaces are precision ground  
Vertical 'V' in movable jaw

### SPECIFICATIONS:

Catalogue No.	Size (L x W x H)
MV - 6	150 * 115 * 75
MV - 8	200 * 125 * 85



## MAGNETIC 'V' BLOCK

These Magnetic -Vee blocks are invaluable and versatile tools with high magnetic power. They can be used for drilling and grinding (both wet and dry) also for light milling work. The V Blocks have three magnetic surfaces. Top and bottom each with 90-degree v - angle and end surface opposite from switch.

All three magnetic surfaces as well as the two sides are carefully ground. Their accuracy for flatness, parallelism and squareness is within 0.005 mm till 6" size and 0.010 mm for 8".  
\* S in catalogue no denotes soft and H stands for hardened.



### SPECIFICATIONS:

Catalogue No.	Size (L x W x H)	Clamping capacity	Magnetic efficiency
MVS - 2 /MVH - 2	55 * 50 * 60 mm	5 - 35 mm	50 kg
MVS - 3/MVH - 3	75 * 65 * 85 mm	5 - 55 mm	75 kg
MVS - 4/MVH - 4	100 * 75 * 95 mm	5 - 65 mm	150 kg
MVS - 6/MVH - 6	150 * 85 * 100 mm	8 - 80 mm	250 kg
MVS - 7/MVH - 7	150 * 125 * 125 mm	10 - 120 mm	350 kg
MVS - 8/MVH - 8	200 * 150 * 150 mm	10 - 150 mm	450 kg

We also manufacture v - blocks in 120-degree angle on request.

Other products: Electromagnetic permanent chucks, Magnetic sine table, Magnetic V blocks for boring bars. V blocks & Vices are supplied with calibration certificate.



# ROLLER BEARING 'V' BLOCK

Used for checking heavy and odd shaped round jobs.  
 Perfectly matched pair having accuracy 0.010 mm  
 Included angle of rollers is 90°  
 Standard bearings are used which are replaceable  
 Supplied with calibration certificate



## SPECIFICATIONS:

Catalogue No.	Size (L x W x H)	Range	Load capacity
RBV - 6	150 * 60 * 100	10 - 55 mm	1000 kg

\*Size up to 300 mm manufactured

# V - BLOCK HARDENED (with clamp)

The V - Blocks have two V - angles of different size to take parts of varying dimensions.  
 By means of the clamp the Work can be held tight in the block. The accuracy of the V block/100mm is within 0.005 mm. Supplied with calibration certificate

## SPECIFICATIONS:

Catalogue No.	Size (L x W x H)	Clamping Range
VH - 2	050 * 040 * 040 mm	05-30 mm
VH - 3	075 * 060 * 060 mm	06-50 mm
VH - 4	100 * 080 * 080 mm	06-70 mm
VH - 3A	070 * 140 * 140 mm	10-125 mm
VH - 6	150 * 200 * 200 mm	10-150 mm
VH - 8	200 * 200 * 200 mm	10-200 mm



\*V-blocks can be supplied with 120 degree angle on request.

# ANGULAR TIGHTENING GRINDING VICE

The vice is very useful for light machining, grinding, inspection of precision components. It can be used standing on its base, sides, end or even on top.  
 We maintain accuracy of  $\pm 0.005$  mm for parallelism and squareness. Manufactured from high grade oil hardening steel, hardened and tempered to ensure stability & accuracy throughout working life.  
 Supplied with calibration certificate

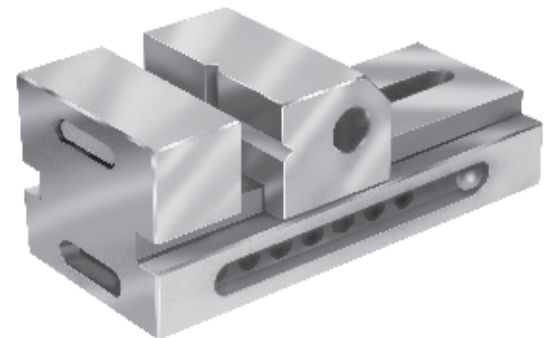

## SPECIFICATIONS:

Catalogue No.	Size (L x W x H)	Clamping range	Accuracy
GV - 7	150 * 50 * 50 mm	0 - 50 mm	0.005 mm
GV - 8	175 * 65 * 65 mm	0 - 75 mm	0.005 mm
GV - 9	200 * 90 * 80 mm	0 - 100 mm	0.005 mm
GV - 10	225 * 100 * 80 mm	0 - 125 mm	0.010 mm
GV - 11	250 * 120 * 100 mm	0 - 150 mm	0.010 mm



**Trade Combine**  
 20, Industrial House, Floor 4,  
 51/ 53, Nagdevi Cross Lane,  
 Mumbai - 400 003. Maharashtra.  
 India.

Tel No : 00-91-22-2345 3999  
 00-91-22-2346 5999.  
 Mobile No : 00-91-99675-47478.  
 E-mail : sales@tradecombine.com  
 Website : www.tradecombine.com